

## The standard for the kraft industry.

*A versatile, high  
production roll  
clamp for heavy  
kraft, linerboard  
and coated  
stocks.*

### APPLICATIONS

The 90F and 100F Paper Roll Clamps are designed for operations that handle large, heavy rolls such as kraft, linerboard and heavily coated stocks. They are application rated and field proven for demanding operations. Available load capacities range from 9,000 to 11,000 lbs. depending on the model, with roll diameters ranging from 51" to 84".

### FEATURES

#### **Reduced Roll Damage**

- Proven contact pad shape and surface holds rolls securely
- Positioned Short Arm and Swing Frame models maintain thin arm profile over a wide range of roll diameters, easing roll breakout and permitting close stacking

#### **Fast Roll Handling**

- Good visibility through and around clamp
- Continuous 360° rotation

#### **Excellent Durability**

- Unitized construction provides structural integrity in arms and frame
- Proven, heavy-duty rotator drive train
- Pivot bushings are lube-free and provide longer service life

### MODELS

#### **Fixed Frame/Fixed Short Arm**

- Excellent arm profile when handling rolls near max. diameter.

#### **Fixed Frame/Positioned Short Arm**

- Good arm profile over a wide range of roll diameters.

#### **Swing Frame/Positioned Short Arm**

- Improves handling in tight stacking locations such as boxcar breakout, allows easy lateral positioning
- Arms can be positioned to equal length configuration

#### **Split Arm**

- The two long arm sections move independently, allowing you to handle two different size rolls simultaneously.

### OPTIONS

- AFC (Adaptive Force Control) for automatic control of clamping pressure that changes as roll weight changes
- 180° mechanical stop group
- Electronic Rotational Control for precise 180° and 90° (bilge) positioning
- Adjustable bumper that ensures rolls are correctly positioned between the pads, not trapped in the arms
- Wide variety of rubber, urethane and other pads are available for improved handling of certain papers

# 90F/100F PAPER ROLL CLAMP

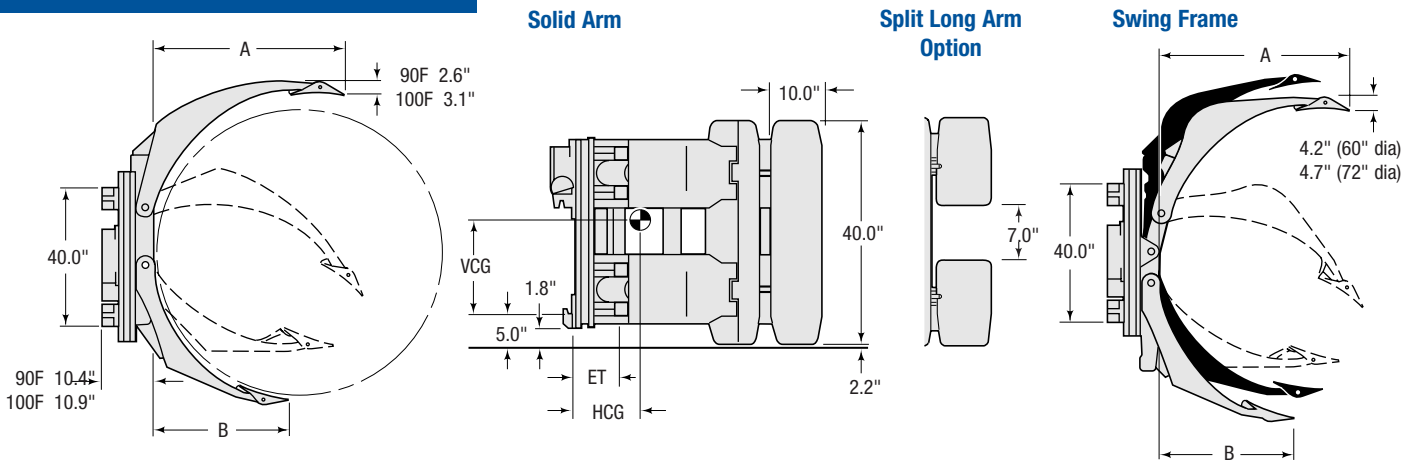

Capacity @ Diameter		Roll Range	Type	Catalog Order No.	Mtg. Class	Mtg. Angle ①	Weight		Effective Thickness ET	Horizontal Ctr. of Gravity HCG	Vertical Ctr. of Gravity VCG	Long Arm Length A	Short Arm Length B
lbs @ inches	kg @ mm						lbs	kg					
<b>Model 90F</b>													
9,900 @ 51"	4,495 @ 1,295	22"-51"	Fixed Short Arm	<b>90F-RCF-08C</b>	IV	2°	2,715	1,233	7.8"	11.2"	22.0"	35.5"	22.3"
9,900 @ 51"	4,495 @ 1,295	10"-51"	Positioned Short Arm	<b>90F-RCP-07C</b>	IV	2°	2,735	1,242	7.8"	11.2"	22.0"	35.5"	22.3"
9,000 @ 60"	4,085 @ 1,525	21"-60"	Fixed Short Arm	<b>90F-RCF-02C</b>	IV	2°	2,830	1,285	7.8"	12.2"	22.0"	38.0"	26.7"
9,000 @ 60"	4,085 @ 1,525	10"-60"	Positioned Short Arm	<b>90F-RCP-01C</b>	IV	2°	2,850	1,294	7.8"	12.2"	22.0"	38.0"	26.7"
9,000 @ 60"	4,085 @ 1,525	10"-60"	Swing Frame w/ Positioned Short Arm	<b>90F-RCS-21C</b> ②③	IV	2°	3,050	1,385	7.9"	12.0"	22.0"	39.0"	26.6"
7,500 @ 72"	3,405 @ 1,830	26"-72"	Fixed Short Arm	<b>90F-RCF-04C</b>	IV	2°	3,030	1,376	7.8"	13.3"	22.0"	43.6"	32.1"
7,500 @ 72"	3,405 @ 1,830	14"-72"	Positioned Short Arm	<b>90F-RCP-03C</b>	IV	2°	3,050	1,385	7.8"	13.3"	22.0"	43.6"	32.1"
<b>Model 100F</b>													
11,000 @ 51"	4,995 @ 1,295	10"-51"	Positioned Short Arm	<b>100F-RCP-07C</b>	IV	2°	2,830	1,285	8.3"	11.5"	19.5"	35.5"	22.5"
10,000 @ 60"	4,540 @ 1,525	21"-60"	Positioned Short Arm	<b>100F-RCP-01C</b>	IV	2°	3,010	1,367	8.3"	12.4"	19.5"	37.8"	26.7"
10,000 @ 60"	4,540 @ 1,525	10"-60"	Swing Frame w/ Positioned Short Arm	<b>100F-RCS-21C</b> ②③	IV	2°	3,540	1,607	9.4"	12.5"	19.5"	37.9"	26.7"
8,500 @ 72"	3,860 @ 1,830	15"-72"	Swing Frame w/ Positioned Short Arm	<b>100F-RCS-23C</b> ②③	IV	2°	3,840	1,743	9.4"	14.7"	19.5"	45.5"	31.4"
8,500 @ 72"	3,860 @ 1,830	27"-72"	Positioned Short Arm	<b>100F-RCP-03C</b>	IV	2°	3,300	1,498	8.3"	13.5"	19.5"	43.8"	32.2"
7,300 @ 84"	3,315 @ 2,135	35"-84"	Positioned Short Arm	<b>100F-RCP-05C</b>	IV	2°	3,580	1,625	8.3"	14.5"	19.5"	49.8"	37.2"

- ① 2° mounting provides reduced effective thickness (Lost Load) and ease in handling horizontal (bilge) rolls. 0° mounting must be used when stacking above 300".
- ② Includes ribbed cast pads. Requires 2,300 PSI operating pressure.
- ③ Swing frame clamps require a Control Valve Group and 3-function hosing over the mast.
- ▶ Cascade Cast Pad is standard.
- ▶ Split Arm available. Consult Cascade for specifications.

## INSTALLATION KIT

Model	Hose Size	Catalog Order No.
Fixed Frame	#6	<b>675158</b>
Swing Frame	#6	<b>675157</b>
Fixed	#6 & #8 ⑤	<b>396189</b>
Swing	#6 & #8 ⑤	<b>396188</b>

⑤ Recommended to maintain maximum flow to rotator motor.

## ROTATOR SPECIFICATIONS

Rotator Speed	Rotator Torque
3.2 RPM @ 15 GPM	128,000 Inch-Lbs. @ 2300 PSI

▶ Optional motors providing faster rotation are available. Reduced torque will result.

## HYDRAULIC FUNCTIONS

Model	Hydraulic Functions	Truck Aux. Valves Required
Fixed Frame	2	2
Swing Frame	3	2

## HYDRAULIC FLOW & PRESSURE

Minimum Flow	Recommended Flow	Maximum Flow (rotate)	Maximum Flow (clamp)	Maximum Pressure
10 GPM	15 GPM	15 GPM	20 GPM	2,300 PSI/159 bar