

An easy, ergonomic way to change relief settings.

APPLICATIONS

Multi-setting Relief Valves are popular options for controlling hydraulic clamping pressure. This three pressure setting system is used for controlling clamp force in roll clamp and carton clamp applications when multiple settings are required to prevent overclamping.

The electronic pressure regulator system offers a solution to the ergonomics of switch location.

BENEFITS

- The valve bank can be located closest to the hydraulic components of the lift truck, allowing ease of installation.
- Maximum operator convenience! The switch can be located near the driver in a convenient location. This will allow the driver to stay in the drive position when changing a pressure setting rather than bending forward to switch the pressure with the mechanical handle. No aggravation to the back, which will encourage the driver to use the relief system.
- Driver will always know which relief setting is active with the in-cab light box.
- Optional light tower can be mounted in best location for supervisor observation.

FEATURES

- A solenoid-operated valve assembly with three independent pressure settings or full truck pressure when no relief setting is activated.
- Ergonomically located control switch.
- A small in-cab light bar to show the driver which relief setting is active. Lights are bright and visible from 40 feet.
- Optional light tower that's visible from a long range showing which relief setting is active.
- All necessary electrical wiring and circuit protection fuse.

ELECTRONIC PRESSURE REGULATOR SYSTEM

Without Light Tower

Truck Voltage	Catalog Order No.	Pressure Control
12 Volt	6050694	500-2400 PSI, adjustable
24-48 Volt	6050695	500-2400 PSI, adjustable

With Light Tower

Truck Voltage	Catalog Order No.	Pressure Control
12 Volt	6050088	500-2400 PSI, adjustable
24-48 Volt	6050464	500-2400 PSI, adjustable

Ergonomic solution for ease of driver operation.

INCLUDED WITH THE ELECTRONIC PRESSURE REGULATOR SYSTEM



Valve Assembly

Solenoid-operated valve assembly with three independent and user defineable pressure settings.



Wiring and Circuit Protection Fuse

All necessary electrical wiring and circuit protection fuse.



Control Switch

Rotary Control Switch to select pressure setting.



In-Cab Light Bar

Small in-cab light bar to show the driver which setting is active



Optional Light Tower

Pressure Indicator Lights, visible from a long range, correspond to the pressure setting that is active.

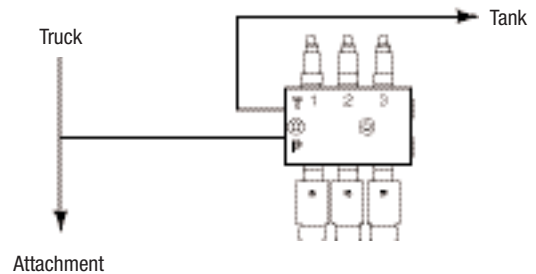

Dimensional Detail

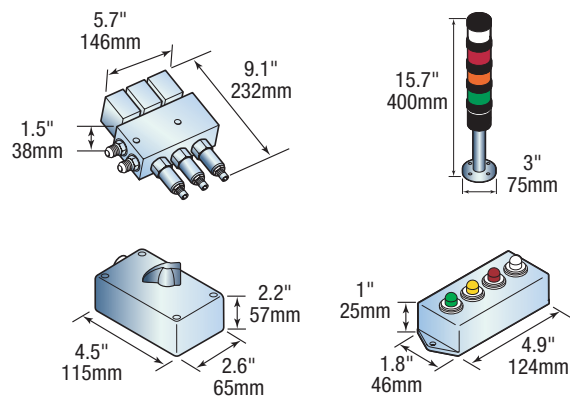

RECOMMENDED ACCESSORIES



Low Pressure Tank Line Kit

Includes hose and hardware necessary to install a hydraulic line directly into an existing low pressure tank line hose.

Tank Line Hose ID	Part No.
0.75 in. (19 mm)	214062
1.00 in. (25 mm)	211745
1.25 in. (32 mm)	214066
1.50 in. (38 mm)	6037507

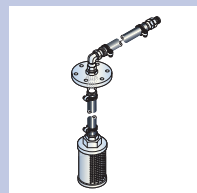

Universal Low Pressure Tank Line Kit

Includes 1/2" hoses, fittings and diffuser to install low pressure tank line kit directly to the top of the hydraulic tank cover. This does not require cutting into the hydraulic return line, and provides excellent efficiency.

Part No. 6046144

The use of low pressure tank line kits is required for optimal performance and system accuracy.



Quick Disconnect Pressure Gauge

High quality, 0-5,000 psi, glycerin filled gauge for accurate readings of hydraulic pressures. Use with test point QD fitting kit.

Part No. 6034612

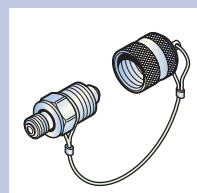

Test Point QD Fitting Kit

Quick disconnect No. 4 adapter fittings to install in Cascade attachment valve or cylinder gauge access ports. Use with quick disconnect pressure gauge.

Part No. 6034611 - includes 4 fittings

Part No. 6004478 - includes 1 fitting