

## Guard against accidental unclamping.

### APPLICATIONS

The Clamp Open Guard system is recommended for use on all F- and G-Series Paper Roll Clamps and D-Series Sliding Arm Clamps to provide an added level of security to prevent accidental load dropping. Clamp Open Guard requires a definitive action by the driver to help prevent accidental unclamping.

### FEATURES

- The driver activates the unclamp system when he is ready to unclamp the load.
- LED light indicates when load can be unclamped.
- Easily installed in the clamp system.
- No calibration required.

### HERE'S HOW IT WORKS

1. During normal operation the clamp open circuit is deactivated. The driver can move the clamp open handle but the system remains clamped on the load.
2. When the driver wants to unclamp the load, he pushes a button to activate the unclamp mode. When activated, the clamping system will remain active for 10 seconds, allowing the clamping arms to be opened.
3. After 10 seconds, the system is deactivated and does not allow unclamping without pushing the unclamp activation button.
4. See notes section for additional system detail.



Yellow light: Power on.



Green light: Unclamp circuit enabled.

*Reduce the costs  
of damage from  
premature  
unclamping.*

## SYSTEM COMPONENTS

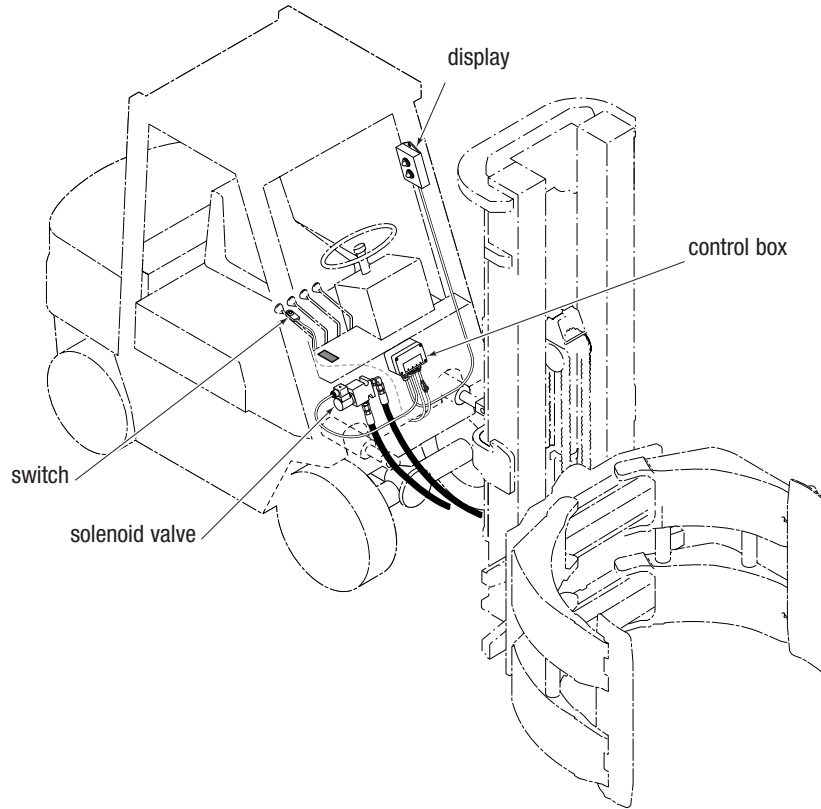

---

## NOTES ON SYSTEM OPERATIONS

- A. The clamp will always be able to close or clamp on the load without pushing any buttons.
- B. The driver will be required to push the unclamp button to open the clamp arms without the arms clamped on a load.
- C. The system can not be overridden by holding the button down.
- D. The 10-second period that the system is deactivated can be adjusted to be longer or shorter.